

motore motor	codice code	P _n kW	T _{no} Nm	T _n Nm	T _p Nm	J kgcm ²	N _{nom} RPM	N _{max@2T_{no}} RPM	N _{max@T_p} RPM	I _{no} ARMS	I _n ARMS	I _p ARMS	N. poli No. poles	W kg
HTQ 300 S TENV	1A	2,25	155	143	400	905	150	136	80	7,1	6,8	20,7	22	155
	3A	4,28	155	136	400	905	300	267	172	13,2	11,6	37,1	22	155
	4A	5,79	155	123	400	905	450	397	261	19,3	15,1	53,6	22	155
HTQ 300 M TENV	1A	4,09	290	261	800	1588	150	134	81	12,3	11,4	38,1	22	240
	3A	7,36	290	234	800	1588	300	258	165	22,7	18,5	69	22	240
	4A	8,94	290	190	800	1588	450	396	257	34,5	22,5	103,5	22	240
HTQ 300 L TENV	1A	5,85	410	372	1200	2271	150	134	82	17,4	15,8	55,7	22	320
	3A	10,00	410	318	1200	2271	300	263	167	32,6	25,2	103,5	22	320
HTQ 300 S TEWC	1B	3,72	250	237	400	905	150	136	100	14,2	13,5	25	22	155
	3B	6,84	250	218	400	905	300	279	210	26,3	23,4	46,9	22	155
	4B	9,43	250	200	400	905	450	415	318	39,2	31,3	68,3	22	155
HTQ 300 M TEWC	1B	8,62	580	549	800	1588	150	150	121	36,6	34,9	55,6	22	240
	3B	16,32	580	520	800	1588	300	285	233	66,8	59,6	100,1	22	240
	4B	22,08	580	469	800	1588	450	436	357	100,1	80,6	150,2	22	240
HTQ 300 L TEWC	1B	12,38	830	788	1200	2271	150	146	115	50,1	47,5	79	22	320
	3B	23,20	830	739	1200	2271	300	291	234	96,7	84,7	150,2	22	320

100423/A - HOLLOW VERSION B14 (OPTION)

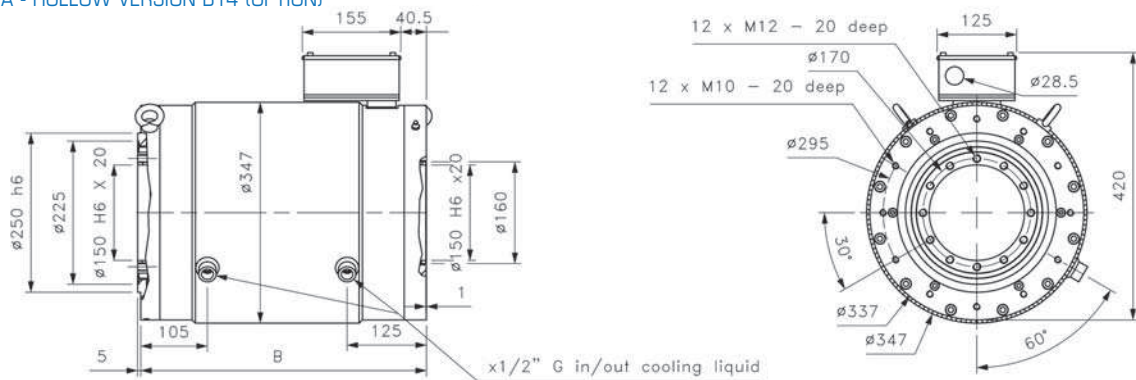

100422/B - SHAFT END VERSION B3 (STANDARD)

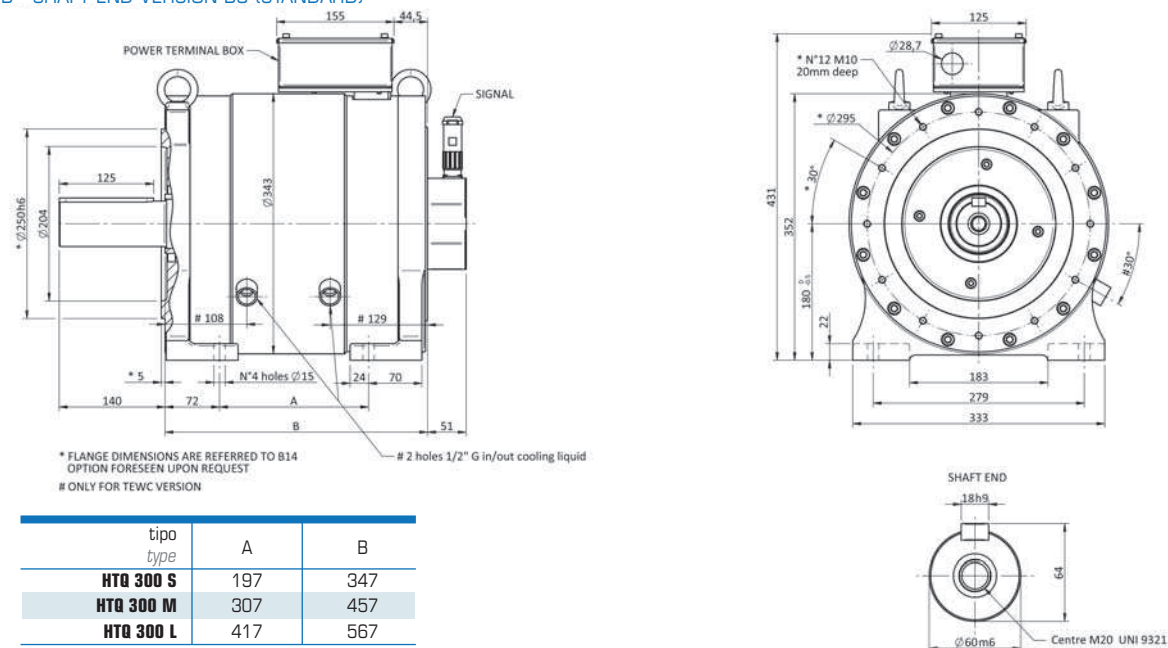

CATALOGO PRELIMINARE:

I dati e le prestazioni sono indicativi e sono soggetti a variazioni e/o modifiche senza preavviso.

PRELIMINARY CATALOGUE:

Data and performances are provided as a guide and can be changed without notice.