

HTQ 350

motore motor	codice code	P _n kW	T _{no} Nm	T _n Nm	T _p Nm	J kgcm ²	N _{nom} RPM	N _{max@2T_{no}} RPM	N _{max@T_p} RPM	I _{no} ARMS	I _n ARMS	I _p ARMS	N. poli No. poles	W kg
HTQ 350 S TENV	1A	7,2	520	461	2400	9400	150	142	89	18,2	15,9	88	20	399
	3A	11,3	520	358	2400	9400	300	288	210	33,7	23	163	20	399
	4A	7,8	520	166	2400	9400	450	450	406	59,5	18,6	285	20	399
HTQ 350 M TENV	1A	8,4	620	536	2800	11200	150	141	90	21,1	18,2	104	20	452
	3A	12,6	620	401	2800	11200	300	282	206	38,6	25	190	20	452
HTQ 350 L TENV	1A	9,5	700	604	3300	13010	150	150	98	25,2	21,5	127	20	504
	3A	13,8	700	439	3300	13010	300	293	215	45,5	28,2	228	20	504
HTQ 350 S TEWC	1B	18,1	1190	1149	2400	9400	150	150	115	48,4	46,6	104	20	399
	3B	34,1	1190	1086	2400	9400	300	300	253	88,6	80,8	191	20	399
	4B	47,9	1190	1016	2400	9400	450	450	404	134,2	113,3	287	20	399
HTQ 350 M TEWC	1B	22,2	1450	1410	2800	11200	150	150	121	60,5	58,3	127	20	452
	3B	42,6	1450	1354	2800	11200	300	300	256	110,4	100,7	229	20	452
HTQ 350 L TEWC	1B	26,5	1750	1686	3300	13010	150	148	117	69,7	67,1	143	20	504
	3B	50,6	1750	1610	3300	13010	300	300	279	140,5	128,3	287	20	504

100440/A - SHAFT END VERSION B3 (STANDARD)

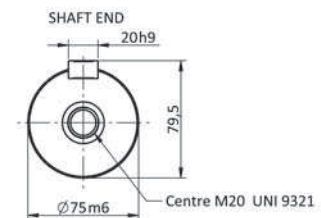
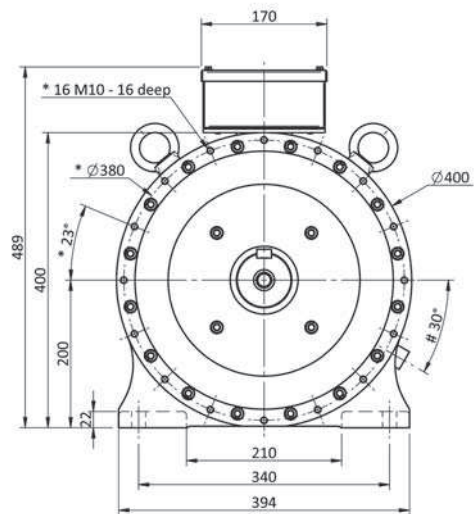
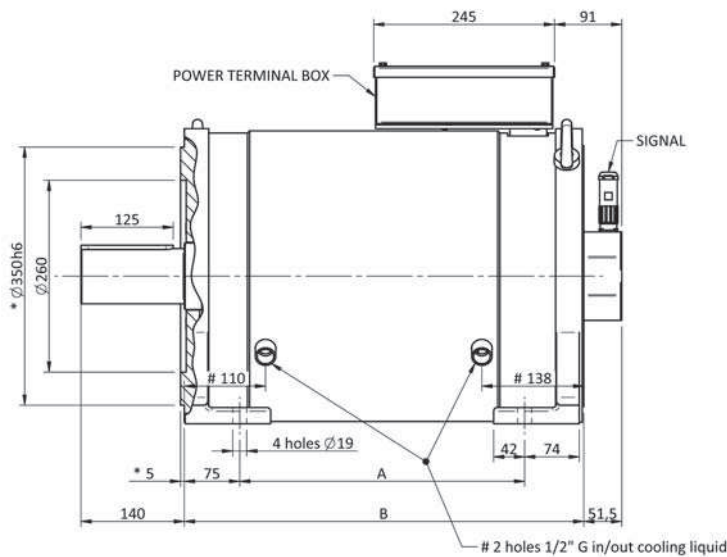

* FLANGE DIMENSIONS ARE REFERRED TO B14
OPTION FORESEEN UPON REQUEST

DIMENSIONS ONLY FOR TEWC VERSION

tipo type	A	B
HTQ 350 S	386	541
HTQ 350 M	446	601
HTQ 350 L	506	661

CATALOGO PRELIMINARE:

I dati e le prestazioni sono indicativi e sono soggetti a variazioni e/o modifiche senza preavviso.

PRELIMINARY CATALOGUE:

Data and performances are provided as a guide and can be changed without notice.